



Air Conditioning & Heating

GGM SERIES

HIGH-EFFICIENCY RETURN GRILLE-MOUNT ELECTRONIC AIR CLEANER

Standard Features

- Pre-filters (2) are constructed of aluminum mesh to prevent lint and large particles from entering the collecting cells
- Collecting cells (2) are constructed of heavy-gauge aluminum for durability and ease of maintenance
- Plastic intake grille is easy to wipe clean
- Hinged, swing-out door allows easy access to filters
- Automatic interlock switch disconnects power when door is opened
- Electronic Air-proving Switch (AS) allows for quick wiring; automatically cycles air cleaner on/off with the system fan
- Performance indicator light (green LED) indicates high voltage to the collecting cells, ensuring air cleaner is operating properly at a glance
- Solid-state power board is manufactured on site for high reliability and long life; uniquely equipped with a variable resistor (potentiometer) to adjust high voltage output, if necessary

Cabinet Features

- Durable powder coat paint finish on heavy gauge steel resists abrasion and provides trouble-free wall or ceiling mount installation
- Holes are provided to facilitate mounting to duct work
- Easily installs on the wall or ceiling in the main return duct of a central forced air heating/cooling system; slides into ceiling box installed within trusses on 24" centers without structural alterations

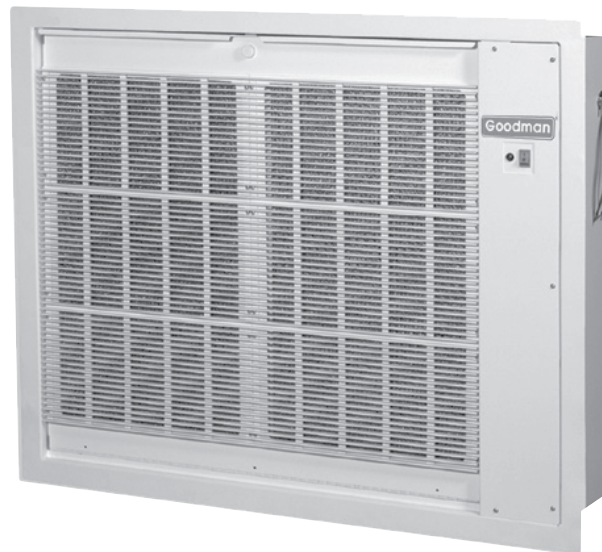

* Complete warranty details available from your local dealer or at www.goodmanmfg.com.



SPECIFICATIONS

Specifications	AGM20AS-A Model
House Size	N/A
Airflow	up to 2000 cfm (up to 3398 m ³ /hr)
Duct Size	22" x 29.1" (55.9 x 73.9 cm)
Cabinet Dimensions	31.4" x 24.4" x 7" (79.8 x 62 x 17.8 cm)
Weight	38 lbs (17.5 kg)
Power	120 v / 60 hz / 30 watts

DIMENSIONS

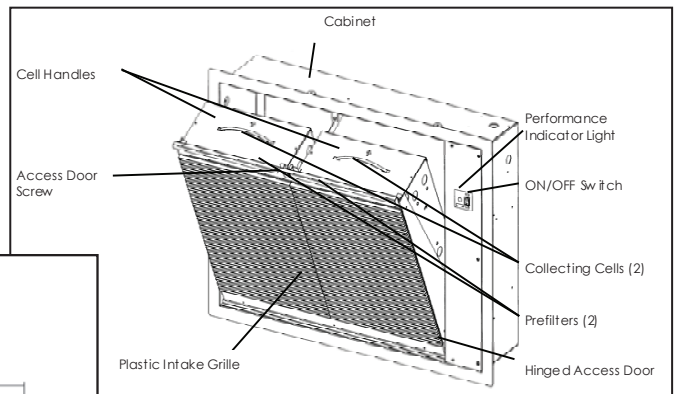
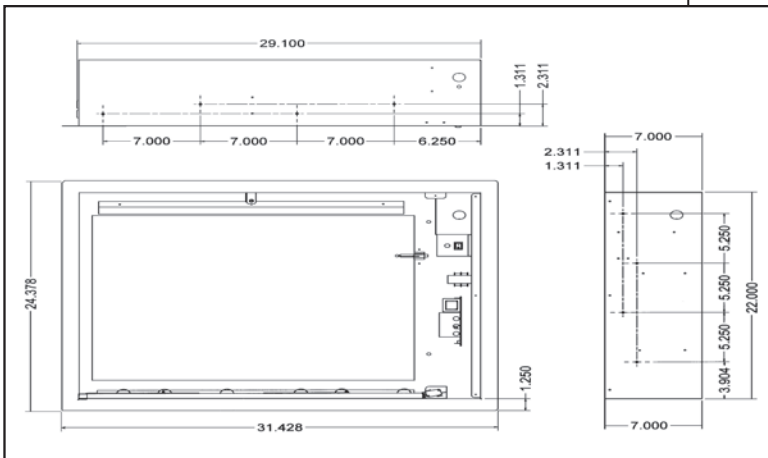

ACCESSORIES

DAX Detergent Size	Part #
32 oz (1 L) Spray Bottle	Part #9900
1.1 gal (4 L) Jug	Part #9901

To keep the lifetime filter system at its best, wash collecting cells and pre-filters with DAX Electronic Air Cleaner Detergent.

FOR MORE INFORMATION, CALL THE AIR CLEANER HELP LINE TOLL FREE @ 1-800-267-8305



Goodman Manufacturing Company, L.P., reserves the right to discontinue, or change at any time, specifications or designs without notice or without incurring obligations. © 2010 • Goodman Manufacturing Company, L.P. • Houston, Texas • Printed in the USA.

